

1

2

3

4

5

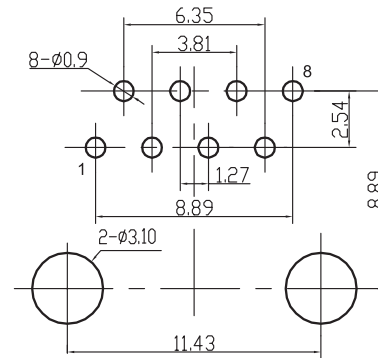

PCB LAYOUT - COMPONENT VIEW

TECHNICAL CHARACTERISTICS

MATERIAL
 INSULATOR MATERIAL: PBT
 FLAMMABILITY RATING: UL94-V0
 COLOR: BLACK
 CONTACT MATERIAL: COPPER ALLOY
 CONTACT TYPE: STAMPED
 CONTACT PLATING: GOLD
 QUALITY CLASS: 500 MATING CYCLES

ENVIRONMENTAL
 OPERATING TEMPERATURE: -40°C UP TO 85°C
 COMPLIANCE: LEAD FREE AND ROHS

ELECTRICAL
 CURRENT RATING: 1.5 A
 WORKING VOLTAGE: 120 VAC
 INSULATION RESISTANCE: $>500\ \text{M}\Omega$
 DIELECTRIC WITHSTANDING VOLTAGE: 1 000 VAC/MIN
 CONTACT RESISTANCE: 20 m Ω MAX

STANDARD

CERTIFIED: E324776

SOLDERING
 JEDEC LEAD FREE WAVE SOLDERING PROCESS

PACKAGING
 TRAY

A

B

C

D

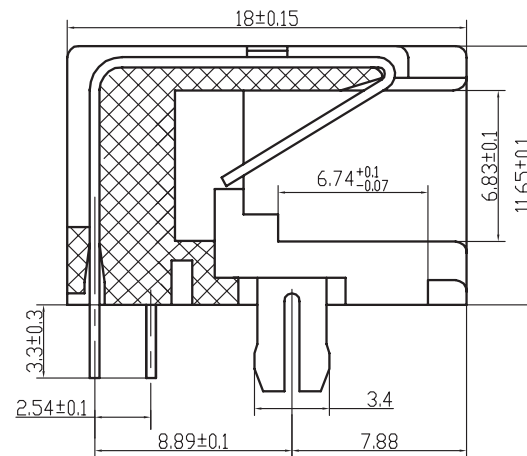
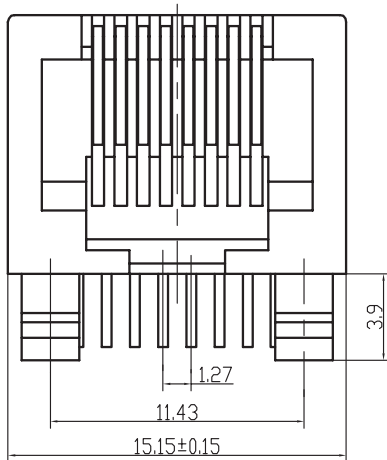

RoHS Compliant

REV	DATE	FILE	BY
A	20-NOV-07	PDF	CH
B	15-FEB-08	MOHM/mOHM UNITS	CH
C	07-OCT-09	UL STANDARD	JP
D	09-JUN-11	HOLE DIMENSION	GG
E	26-SEP-13	TEMP UPDATE	QL
F	03-JAN-14	TPK DIM ADD	QL
G			

PROJECTION:

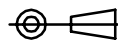

APPROVAL: RJ

GENERAL TOLERANCE

.X = \pm 0.2
 .XX = \pm 0.15

UNIT: MM

SCALE:

SHEET: 1/1

DRAW:



DESCRIPTION: HORIZONTAL PLASTIC 8P8C MODULAR JACK TAB DOWN

WERI PART NO: 615 008 137 121

SIZE

A4

1

2

3

4

5

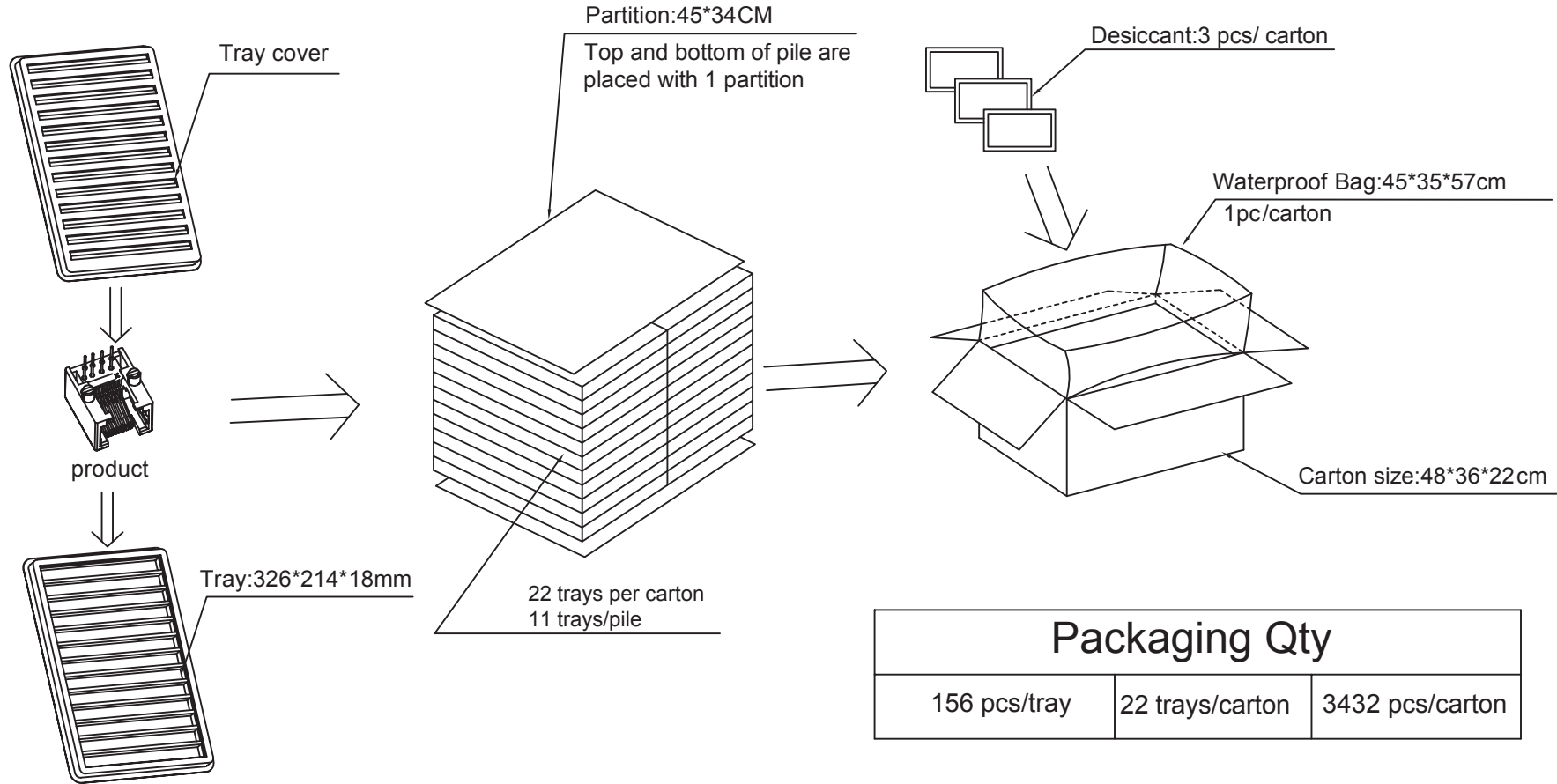

A

B

C

D

RoHS Compliant			
G			
F			
E			
D			
C			
B			
A			
REV	DATE	FILE	BY

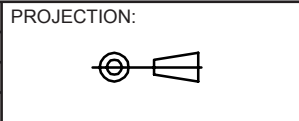

GENERAL TOLERANCE

.X = +/- 0.2

.XX = +/- 0.15



APPROVAL: RJ

UNIT: MM

SCALE:

SHEET: 1/1

DRAW:

DESCRIPTION: HORIZONTAL PLASTIC 8P8C MODULAR JACK TAB DOWN

WERI PART NO: 615 008 137 121

SIZE

A4

HandsOn Technology

<http://www.handsontec.com>

creativity for tomorrow's better living...

HandsOn Tech provides a multimedia and interactive platform for everyone interested in electronics. From beginner to diehard, from student to lecturer... Information, education, inspiration and entertainment. Analog and digital; practical and theoretical; software and hardware...



HandsOn Technology support Open Source Hardware(OSHW) Development Platform.

Learn : Design : Share

www.handsontec.com



www.handsontec.com



www.handsontec.com



www.handsontec.com

www.handsontec.com

Welcome to Handsontec Store



LCD+Keyboard Shield

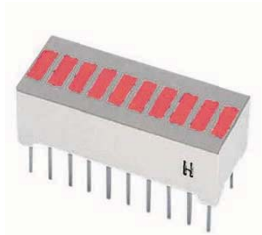

10-Segments LED Bar Display

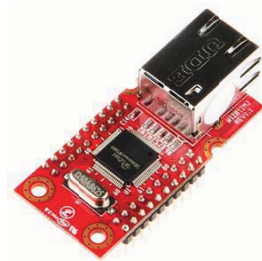

Ethernet Module



Arduino Uno



MicroSD Breakout Board

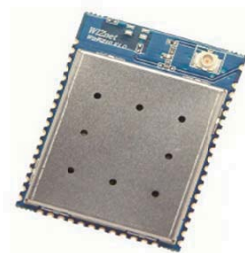

WiFi Module



20x4 LCD Display Module



Stepper Motor Driver

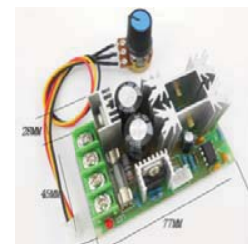

PWM Motor Speed Controller



www.handsontec.com

Breakout Board & Modules



www.handsontec.com

Integrated Circuits



www.handsontec.com

Discrete Parts



www.handsontec.com

Assembled Kits



www.handsontec.com

Connectors